

THIS DRAWING IS UNPUBLISHED. RELEASED FOR PUBLICATION, 19  
 © COPYRIGHT 19 BY AMP INCORPORATED. ALL INTERNATIONAL RIGHTS RESERVED.

LOC	DIST	P	F	REVISIONS				
				ZONE	LTR	DESCRIPTION	DATE	APPD
AF	50				F	REV PER 0250-94	5/27/94	JR/CM

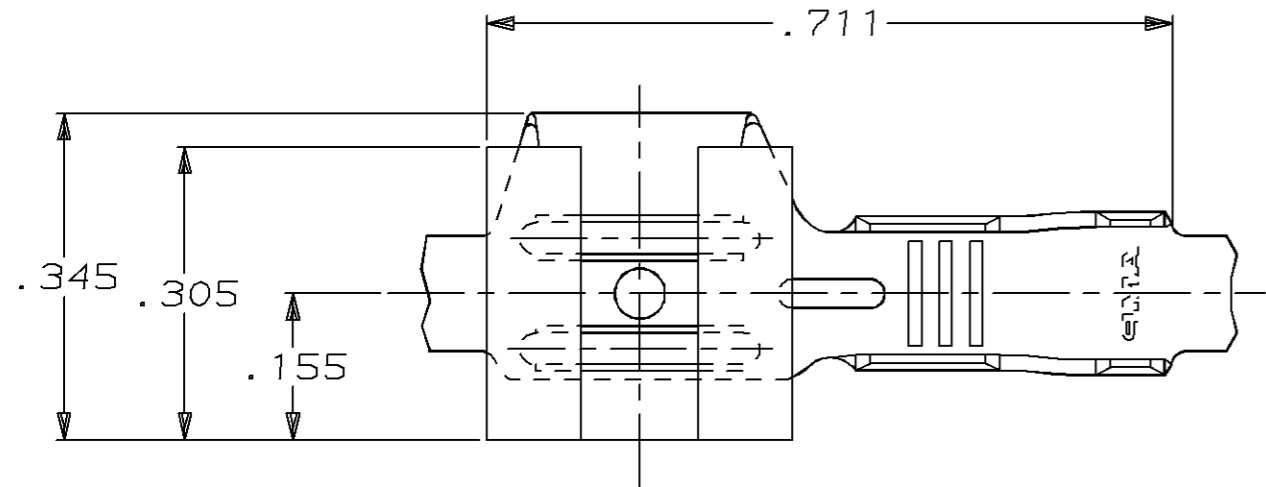

1 CONTINUOUS STRIP ON REELS.  
 2 TIN PLATE .000080 MIN THK

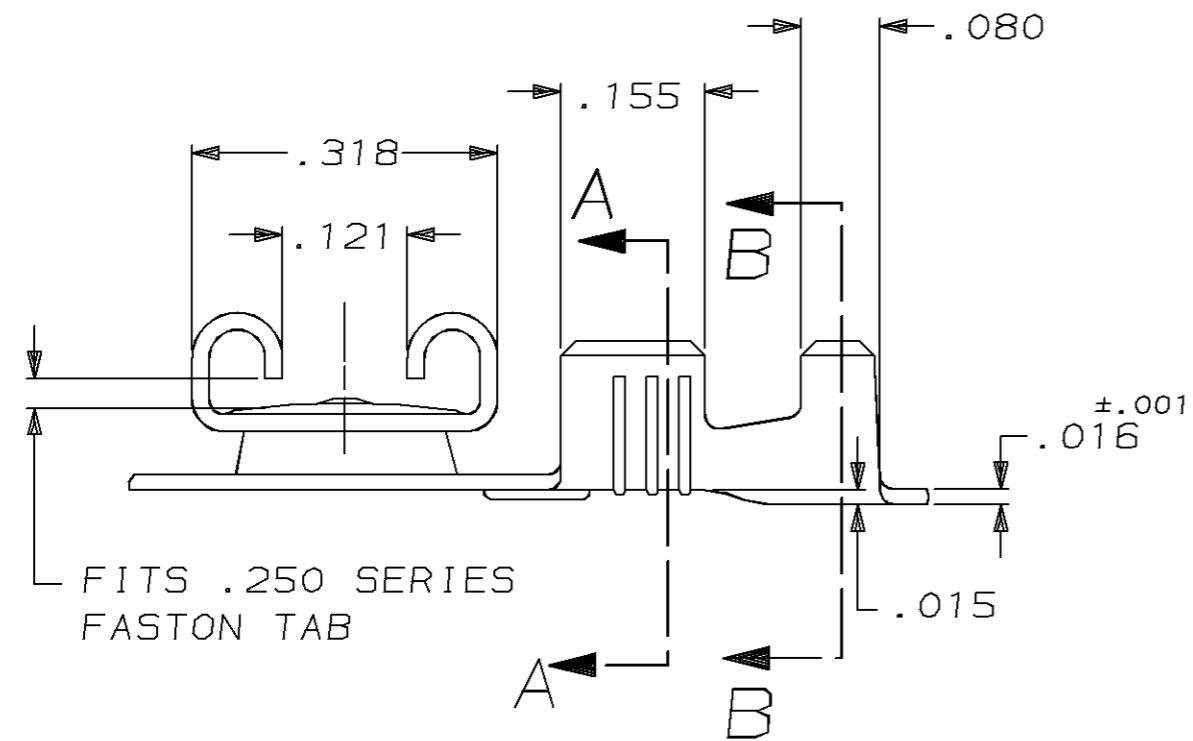

FITS .250 SERIES FASTON TAB

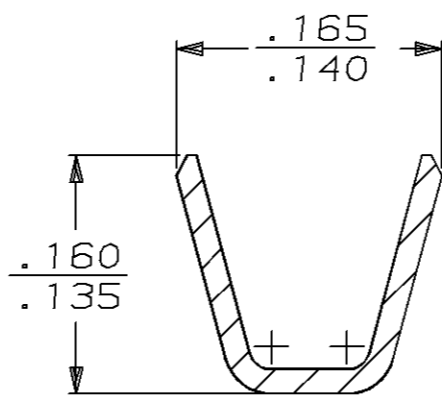

SECTION A-A  
SCALE 8:1

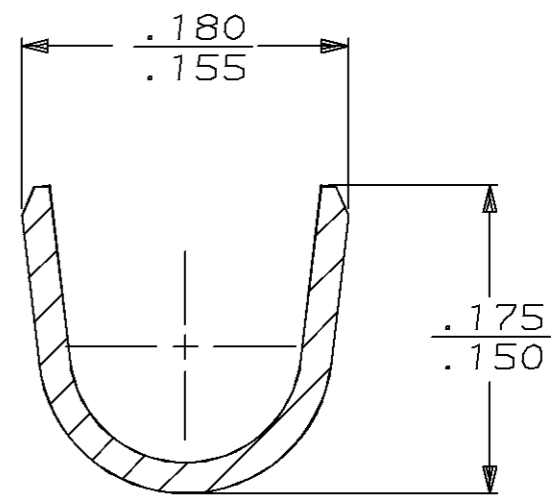

SECTION B-B  
SCALE 10:1

TIN 2	.090.-130	18-14	.032	62048-2
-	.090.-130	18-14	.032	62048-1
FINISH	INSUL RANGE	WIRE SIZE	MATING TAB THK ±.001	PART NO

DO NOT SCALE PRINT. UNLESS SPECIFIED DIMENSIONS ARE IN INCHES. TOLERANCES ON: 2 PLC DEC ± - 3 PLC DEC ± .015 ANGLES ± -	DR 6/7/91 JR RUTH	<b>AMP</b> AMP INCORPORATED Harrisburg, Pa. 17105 NAME RECEPTACLE, FASTON™ FLAG, REVERSIBLE, .250 SERIES
	CHK 6/7/91 MS FEHER	
APPD 6/7/91 C MEYERS		
APPD 6/7/91 R KUZO		
MATERIAL 4M BRASS	PRODUCT SPEC -	SIZE <b>B</b>
FINISH SEE TABLE	APPLICATION SPEC 114-2032	CAGE CODE 00779
	WEIGHT -	DRAWING NO 62048
		SCALE 5:1
		SHEET 1 OF 1